

Carrosserierungen

DIN 9021

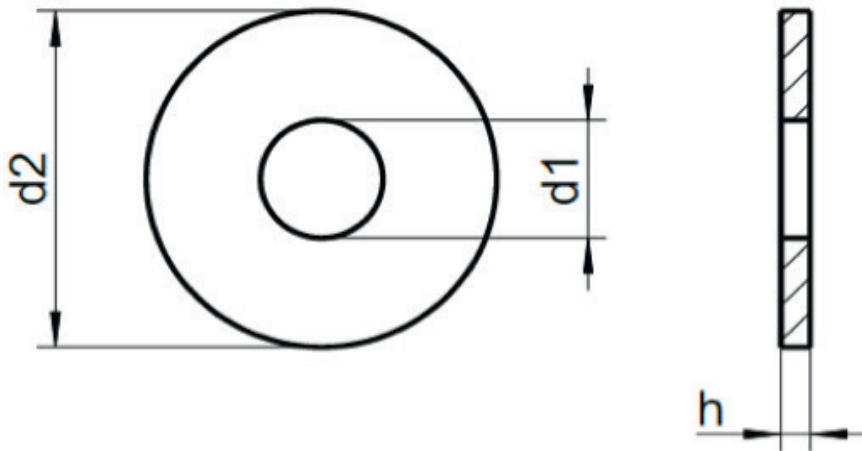

| d | d1 | d2 | h |
|----------|-----------|-----------|----------|
| M 3 | 3.2 | 9 | 0.8 |
| M 4 | 4.3 | 12 | 1.0 |
| M 5 | 5.3 | 15 | 1.2 |
| M 6 | 6.4 | 18 | 1.6 |
| M 8 | 8.4 | 24 | 2.0 |
| M 10 | 10.5 | 30 | 2.5 |
| M 12 | 13.0 | 37 | 3.0 |
| M 16 | 17.0 | 50 | 3.0 |
| M 20 | 22.0 | 56 | 4.0 |